

BLACK FOLDER FILE COPY

TRONCATRICE A DISCO PER METALLI FERROSI
CUTTING-OFF MACHINE WITH CIRCULAR BLADE FOR FERROUS METALS
METALL-KREISSAEGE
TRONÇONNEUSE A DISQUE POUR METAUX FERREUX
CORTADORA DE DISCO PARA METALES FERROSOS

MANUALE DI ISTRUZIONI PER L'USO - INSTRUCTION MANUAL FOR OPERATION
BETRIEBSANLEITUNG - MANUEL D'INSTRUCTIONS POUR L'EMPLOI
MANUAL DE INSTRUCCIONES DE USO

COSTRUTTORE:

MANUFACTURER :

ERBAUER:

MACC S.p.A. SCHIO (VI) - ITALY

CONSTRUCTEUR:

CONSTRUCTOR:

MODELLO:

MODEL :

TRS 300

MODELL:

MODELE:

MODELO:

MATRICOLA:

SERIAL NUMBER:

N. 68403

KENNNUMMER:

MATRICULE:

MATRICULA:

ANNO DI COSTRUZIONE:

YEAR OF CONSTRUCTION:

2005

BAUJAHR:

ANNEE DE CONSTRUCTION:

AÑO DE COSTRUCCION :

1. INTRODUCTION

This operation instruction manual conforms to the requirements of the 89/392/EEC Machine Directives and subsequent amendments.

In the light of this, special attention has been given to safety aspects and accident prevention in the work-place for each stage in the machine's "life". Information which could be of particular assistance to the operator has been highlighted. The "Operating instructions" are an integral part of the machine and should be consulted before, during and after the start up of the machine and whenever else required. The content of these instructions should always be carefully observed.

The observance of the above is the only way to achieve the two fundamental aims of this manual:

- Optimization of machine performance
- Prevent damage to the machine and injury to the operator

The index of the chapters and the index of the drawings, diagrams and tables is contained in chapter 3 and can be used to help the location of specific information.

CAUTION : BEFORE INSTALLING THE MACHINE, READ THE OPERATING INSTRUCTIONS CAREFULLY

2. INFORMATION ABOUT MAINTENANCE ASSISTANCE

2.1 GUARANTEE

- M/ACC products are guaranteed against material and manufacturing defects for a period of 12 months from the date of delivery or, if the machine is installed by M/ACC employees, from the date of machine start up.
- The buyer is only entitled to the replacement of parts which are acknowledged as faulty: carriage and packing are at the buyer's expense. In the event of the above, the following information should be supplied:
 1. Date and number of purchasing document
 2. Machine model
 3. Serial number
 4. Code of any relevant drawings
- Requests for compensation for the inactivity of the machine will not be accepted.
- The guarantee does not cover uses which are not in line with these operating instructions which are an integral part of the machine. Nor is maintenance covered if the instructions supplied are not observed.
- The guarantee will not cover machines which have undergone unauthorized modifications.
- Modification or tampering with the safety devices is strictly forbidden.

3. INDEX

3.1 INDEX OF CHAPTERS

Chap. 1	Introduction
Chap. 2	Information about maintenance assistance
Chap. 3	Index of chapters, drawings, diagrams and tables
Chap. 4	Description of the machine Safety standards complied with during the design and construction of the machine Description of the machine and its components
Chap. 5	Main technical data
Chap. 6	Handling and transportation
Chap. 7	Installation
Chap. 8	Start up and operation Devices and their location Tools supplied Operation Special safety checks General safety rules Measures to prevent residual risks
Chap. 9	Maintenance and repairs General safety measures Routine checks and maintenance Description of routine maintenance
Chap. 10	Information regarding environmental noise
Chap. 11	List of spare parts

3.2 INDEX OF DRAWINGS, DIAGRAMS AND TABLES

ENCL. TYPE	DESCRIPTION	ENCL No.	CHAP.
Table	Choice of circular blade	1	8.3
Drawings	Handling and transportation- Installation plan	1	6/7/8
Drawings	Electrical details	2	7
Diagram	Electrical installation	2	
Diagram	Electrical installation	3	
Drawings	Motor-blade block	3	7/8.3/9
Drawings	Base block and vice	4	8.3/9.3
Drawing	Machine assembly	4	8.3

4. DESCRIPTION OF THE MACHINE

4.1 DESCRIPTION OF THE MACHINE AND ITS COMPONENTS

The TRS 300 cutting-off machine with circular blade for ferrous metals produced by MACC is made from a solid casting, carefully processed and provided with holes for fastening to a bench or pedestal. The upper surface, designed to allow the complete draining away of the cutting fluid, has been processed using precision machinery to allow the attachment of a sturdy vice with burr-proof jaws.

The bar-stop device allows the length required to be preset and a constant level of performance for repeated cuts.

The blade-holding head is firmly attached to a reduction unit in oil bath built onto the motor and to the base by means of a joint which provides 45° rotation both to the left and right and the cutting movement with manual feed.

The coolant pump is also securely attached to the motor block.

The main switch is located above the motor block. Another switch is used to select motor rotation speed and therefore cutting speed.

The control lever, fitted with an ergonomic hand-grip and blade activation button with safety release action, reduces fatigue during operation to a minimum.

The blade is protected by a guard which in its turn protects the operator from ejected shavings and coolant.

The machine is supplied with a set of service spanners.

4.2 INTENDED AND UNSUITABLE USES OF THE MACHINE

The TRS 300 cutting-off machine with circular blade has been designed and built to cut bars, structural steel and ferrous metal pipes in accordance with the instructions contained in this manual.

Therefore, the cutting of other materials is not permitted: if the above recommendations are not observed, the machine could be damaged and the health and safety of the operator put at risk.

Cutting is not permitted, if the bar has not been first locked in the vice.

5. MAIN TECHNICAL DATA

Under no circumstances should the following data be altered, this is in order to protect the correct functioning of the machine and to avoid creating safety risks for the operator.

MOTOR	three-phase or single-phase
Motor Power	three-phase KW 1,1/1,5 - single-phase KW 1,1
Motor revolutions (two speeds)	1400-2800 rpm
CIRCULAR BLADE (SAW)	Number of teeth and feed holes according to table
Maximum diameter and thickness	Diameter: 275 mm Thickness: 2,5
BLADE REVOLUTIONS per minute	40-80 rpm
CUTTING ANGLE	45° right - 45° left
PIECE LOCKING VICE: MAX OPENING	100 mm
COOLANT TANK CAPACITY	litres 3
MACHINE WEIGHT	98 kg - 960 N

6. HANDLING AND TRANSPORTATION

For safe handling and transportation use a lift truck for movement indoors or a bridge crane; in this case, also using cables fastened to the sling positions indicated on the Draw. 1 Encl. 1. Keep the machine in its normal position and avoid turning it upside down. If the machine is fastened to the pedestal, stability will be greatly reduced and therefore all the necessary measures should be taken to stop the machine from tipping over.

All handling and transportation operations should be carried out by trained staff.

7. MACHINE INSTALLATION

A. MACHINE CHECK AND CONTROL LEVER ASSEMBLY

The machine should be checked to make sure that it has not been damaged during transportation and handling.

Control lever assembly (Draw. 5 Encl. 3) : Fit the supplied head lever 29, into position 7 and fasten it by means of the nut 28. To fit the handle, connect the electric cable terminals 220 to the microswitch 218 and place it in the left second half of the handle as shown in Draw. 4 Encl.2. Then insert the button 222 and the lever 29. Complete the assembly using the screws 221 and then 219. Make sure that the cable is inserted into the lever slot 29, after having checked that there are no burrs or sharp edges in the slot.

B. FASTENING OF THE MACHINE

The machine will be able to operate in keeping with the technical parameters supplied by MACC if it is positioned correctly and fastened securely to the bench or the factory floor so that vibrations are minimal during operation . Consult Drawing 2 TRS 300 Installation plan Encl.1.

C. ASSEMBLY OF CIRCULAR BLADE

For the assembly of the circular blade, remove the screw 108 (Draw. 6 Encl. 3), keeping the motor-blade block raised and rotate the mobile guard 15 backwards. Unscrew the screw 42 clockwise, withdraw the flange 22, insert the circular blade, making sure that the toothing faces the same direction as the arrow on the mobile guard. Then refit flange 22 and screw 42.

D. ELECTRICAL CONNECTION TO THE MAINS

Install a differential thermomagnetic switch with characteristics suited to the mains.

Make sure that the power supply voltage corresponds to the voltage on the motor plate. Connect the cable to the power supply line observing the colour codes of the individual wires, pay particular attention to the earth wire. Connect the machine, make sure that the rotation of the circular blade is in the direction shown by the arrow on the guard.

E. CUTTING COOLANT

For the cooling of the circular blade, fill the tank with emulsible oil obtained from a mixture of water and AGIP ULEX 260 EP oil with a percentage of 5-7%

8. MACHINE START UP AND OPERATION

8.1 DEVICES AND THEIR LOCATION

(The location of the devices described is shown on the TRS 300 installation plan Encl. 1)

Code 212	LOCKABLE MAIN SWITCH
Code 218	START-STOP MICROSWITCH: situated inside the handle located at the end of the control lever and has safety release action.
Code 208	EMERGENCY STOP
Code 18	CUTTING ANGLE DEVICE: to check that cutting inclination is as required
Code 6	LOCKING VICE
Code 39	BAR-STOP
Code 29	CONTROL LEVER WITH HANDLE

8.2 TOOLS SUPPLIED

1	Allen wrench size 3
1	Allen wrench size 4
1	Allen wrench size 5
1	Allen wrench size 6
1	Allen wrench size 14

8.3 OPERATION

CHECKS TO CARRY OUT BEFORE EACH CUT

- A. Make sure that the circular blade is fastened securely by means of screw 42 (Draw.6 Encl.3)
- B. Check that the hand indicates the required cutting angle (vice scale)
- C. Make sure that the head and vice are locked by means of the lever 8 (Draw.7-8 Encl.4)
- D. With the motor off, lower the head and check that at the end of the stroke, the circular blade does not touch the counter-vice 4. If the circular blade does touch, adjust the screw 68 located at the centre of the head support 3 (Draw.5 Encl.3)
- E. Make sure that the piece to be cut is adequately secured in the vice.
- F. Make sure that the coolant is circulating in the machine.

CUTTING OPERATION

- A. Before each cutting operation, if the cutting inclination is not as required, correct or change the inclination by placing the bench lever 8 in position 2 (Draw.8 Encl.4) and after correction, forcefully turn it to position 1.
- B. Clamp the piece to be cut by means of the handwheel 34 (Draw.7 Encl.4), turn the main switch 212 and the speed switch 203 to the position required (we recommend No.1), **use the second speed 81 RPM only in case of need and no longer than 5 minutes in 1 hour**. Take hold of the handle 88 located at the end of the head lever and press button 218. The blade will now start turning.
- C. Position the blade carefully on the piece to be cut. Then increase the pressure in order to accelerate the cutting operation without using excessive force. To make a series of cuts, position the bar-stop 39 at the size required. Fix it into position by using the knob 58 (Draw.9 Encl.4).
- D. To replace the circular blade carry out the same operations used to assemble the circular blade. (chapter 7c).
- E. For the choice of most suitable blade consult the table Encl. 1.

We strongly discourage the use of blades with ruined or insufficiently sharp cutting edges

8.4 SPECIAL SAFETY CHECKS

- A. Before using the machine, check carefully that the safety devices are in good working order, that the mobile parts are not blocked, that no parts are damaged and that all the components are installed correctly and are functioning properly.
- B. **Make sure, before operating the machine, that the screws of the guards and other protective devices are adequately secured, especially the screws on the circular blade guard and the rotation levers of the circular blade mobile guard.**
- C. **Check that the safety microswitches and the emergency button are functioning correctly. Test them during a loadless machine cycle.**
- D. **Make sure that the mobile guard does not leave uncovered an angle of more than 5° in order to prevent fingers from entering.**
- E. Pay attention to environmental conditions. Do not expose the machine to rain; do not use it in damp environments, position the machine on a clean dry floor that has no oil or grease stains.
- F. Before using the machine, the operator should make sure that all tools and service spanners used for maintenance or adjustment have been removed.

8.5 GENERAL SAFETY RULES

- A. Wear appropriate clothing. The operator's clothing should not be loose or dangling nor should it have parts which could easily get caught. Sleeves should contain elastic. Belts, rings or chains should not be worn. Long hair should be kept in a net.
- B. Avoid unstable operating positions. Find a safe and evenly balanced position to operate the machine.
- C. Keep the work area tidy, untidiness increases the risk of accidents.
- D. Do not use the power supply cable to disconnect the plug from the socket. Protect the cable from high temperatures, oil or sharp edges. For outdoor use, only use extension cables which are in line with current regulations.

8.6 MEASURES TO PREVENT RESIDUAL RISKS

- A. The removal of guards and tampering with the safety devices is strictly forbidden.
- B. Gloves should always be worn.
- C. Standard work clothing should be used and kept closed and should not have flapping parts.
- D. The machine should not be cleaned with liquids under pressure.
- E. In the event of fire, extinguishers should not be used unless they are the powder type. The electric power supply to the machine should always be disconnected in these circumstances.
- F. Do not insert foreign bodies into the motor cover and do not supply the machine with voltage by tampering with the safety microswitches or main switch.
- G. **Take the necessary precautions to avoid the machine being started by other people during loading, adjustment, piece changing or cleaning.**

9. MAINTENANCE AND REPAIRS

9.1 GENERAL SAFETY MEASURES

- A. Lockable main switch. Open the padlock in the event of machine failure or replacement of the circular blade. The padlock key should be entrusted to a responsible person.
- B. Before carrying out any work on electrical equipment, remove the power supply plug from the control panel (disconnect voltage).
- C. Only use cables to supply power, which have a cross-section suited to the power of the machine.
- D. Opening key. The keys of the machine should be kept by authorized personnel. Do not leave the keys for doors which provide access to the hydraulic or electrical parts or keys to lockable switches in easy of reach of unauthorized personnel.
- E. Repairs should only be carried out by authorized personnel. Only spare parts made by the original manufacturer should be used, otherwise these could cause damage or injury.

9.2 ROUTINE CHECKS AND MAINTENANCE

FREQUENCY (working hours)	OPERATION
1000 hours	Replace the oil in the gear box with AGIP ACER 320 oil (0.2 litres) or equivalent.
1000	Lubrication of mobile parts in the piece locking vice (GREASE AGIP MU 2)
50	Cleaning of the coolant tank and filter check
- if necessary	Check functioning of bench lever

9.3 DESCRIPTION OF ROUTINE MAINTENANCE

A. Replacement of gear box oil

Remove caps 131 and 90 (Draw.5-6 Encl.3), let all the used oil flow out into a container which should have a label indicating the contents for the purposes of disposal. Replace cap 90. Feed 0.2 litres of oil (as specified above) into the oil feed hole located on the upper part of the gear box and then replace cap 131.

B. Lubrication of mobile parts of piece locking vice

Remove jaw 16 (Draw.7 Encl.4), withdraw vice 6 completely by turning hand wheel 34. Clean and grease the parts worked by the counter-vice 4 and vice 6. Put a drop of oil in the oil feed hole 94 located behind the handwheel.

C. Cleaning of the coolant tank: Filter check.

Empty the coolant from the tank by means of the tap located on the rear part of the machine bench (after moving the liquid feed pipe away from this). Collect the coolant in a container for future disposal.

Remove screws 65 and the drilled plate 30 (Draw.8 Encl.4). Clean out the shavings and the metallic powder, taking care not to scatter this over the machine especially around the motor and the box containing the electrical equipment. Refit the plate 30 and fasten it with screws 65, turn the tap off and reconnect the pipe. Check filter 113 and if necessary replace it. Fill the tank with the amount and liquid stated previously.

D Checking of bench lever functioning

Check regularly that the rotation release - locking lever is working properly. In the event of the lever not locking correctly, loosen grub screw 20 (Draw.7 Encl.4), tighten nut 43 and fasten grub screw 20 again. Make sure that with the bench lever in position 2, arm 3 which supports the blade-motor block can rotate freely.

10. INFORMATION REGARDING ENVIRONMENTAL NOISE

An environmental noise test carried out on the TRS 300 cutting-off machine with circular blade, identical to the machine to which these operation instructions refer, has given the following results:

ACOUSTIC RADIATION PRESSURE

1. $L_{Aeq} = 83.2$ dB (A)
2. $L_{peak} = 90.6$ dB (the maximum acceptable value is 140 dB).
3. The level of background noise has no influence = 48.5-54.2 dB (A).

11. LIST OF SPARE PARTS

POS	DESCRIPTION	CODE	POS	DESCRIPTION	CODE
1	Bench	001/05	62	Dowel M8x35 DIN 914	
2	Motor casing		63	Screw M6x12 DIN 912	
3	Head carrying arm	002/18	64	Screw M6x20 DIN 912	
4	Countervice	015/18	65	Screw M6x55 DIN 912	
5	Fan guard		66	Nut M 8 DIN 934	
6	Vice	016/18	67		
7	Head	003/18	68		
8	Bench lever	002/05	69	Screw M 8x16 DIN 912	
9			70	Screw M8x30 DIN 933	
10	Worm screw	016/03	71	Screw M10x25 DIN 933	
11	Helical gear	007/18	72	Dowel M6x10 DIN 914	
12	Rotor		73		
13			74	Nut M 8 DIN.934	
14			75	Washer D.6 DIN 125/A	
15	Disk movable guard fixed rod	011/19	76	Elastic pin 8x36 DIN 1481	
16	Vice jaw	029/05	77	Key 5x5x30 DIN 6885	
17			78	Key 7x8x30 DIN 6885	
18	Graduated scale	024/05	79	Oiler D.6	
19	Vice screw	013/05	80	Snap ring D. 9 E DIN 471	
20			81		
21	Disk shaft	006/18	82		
22	Disk flange	019/03	83	Snap ring D.471 DIN 471	
23	Spacer	014/18	84	Bearing 629	043/05
24	Head gear	045/03	85	Bearing 6302	
25	Head pin	009/18	86	Bearing 6204 ZZ	
26	Countervice pin	010/18	87	Bearing 3204	047/03
27	Washer		88	Head lever handle	046/05
28	Head lever nut M14 DIN 934		89	Oil lever plug	
29	Head lever	039-A/05	90	Oil drain plug	
30	Crucible	037/05	91	Splash guard 32-47-7	005/03
31	Disk guard	010/19	92	Splash guard 25-42-7	
32			93		
33			94		
34	Vice handwheel	029/03	95	Washer	
35	Pump carrier	003/05	96	Self-locking ring nut M 17x1 KM 3	
36			97	Self-locking ring nut M 25x1,5 KM 5	
37	Washer		98		
38	Bar stopper rod	031/05	99	Pump	041/05
39	Bar stopper	004/05	100	Bench tap	042/05
40			101		
41			102	Water pipe	
42	Disk fastening screw	018/05	103	Clamp	
43	Bench lever nut	027/05	104		
44			105	Disk	
45			106	Snap ring D.45 E DIN 471	
46			107	Jet-breaker	030/19
47			108	Screw M 6x16 DIN 912	
48			109	Movable guard rod	027/19
49			110	Screw M6x20 DIN 912	
50			111	Fixed guard rod	017/18
51			112		
52	Fan		113	Filter	045/05
53	Pedestal		114	Screw M6x20 DIN 912	
54	Stator		115	Fixed antifraze braket	025/05
55			116	Dowel M8x25 DIN 915	
56			117	Mobile antifraze braket	030/05
57			118	Washer D.10 DIN 125/A	
58	Handwheel D.40 M 8x25	077/25	119	Screw M10x25 DIN 933	
59	Dowel M6x10 DIN 914		120		
60	Nut M 16 DIN 936		121		
61	Screw 4x12 DIN 912		122		

123			200	Box Cover box	068/90 067/90
124			201	Plate	069/90
125			202		
126			203	Changeover switch	011/90
127			204	RH screw M4x14 DIN 7981	
128			205	HSHC screw M4x6 DIN 912	
129			206		
130			207		
131	Oil filling cap		208		
132	Flange motor		209		
133	Flange rear motor		210	Remote controlled switch	032/90
147	Support box bracket	048/18	211		
			212		
			213		
			214	RH screw M4x14 DIN 7981	
			215		
			216		
			217	Transformer 20 VA	092/90
			218	Micro switch of handle	028/90
			219	HSFHC screw M4x8 DIN 7991	
			220	Electrical cable 2x1	
			221	RH screw M2,9x13 DIN 7981	
			222	Button	

TRS 300

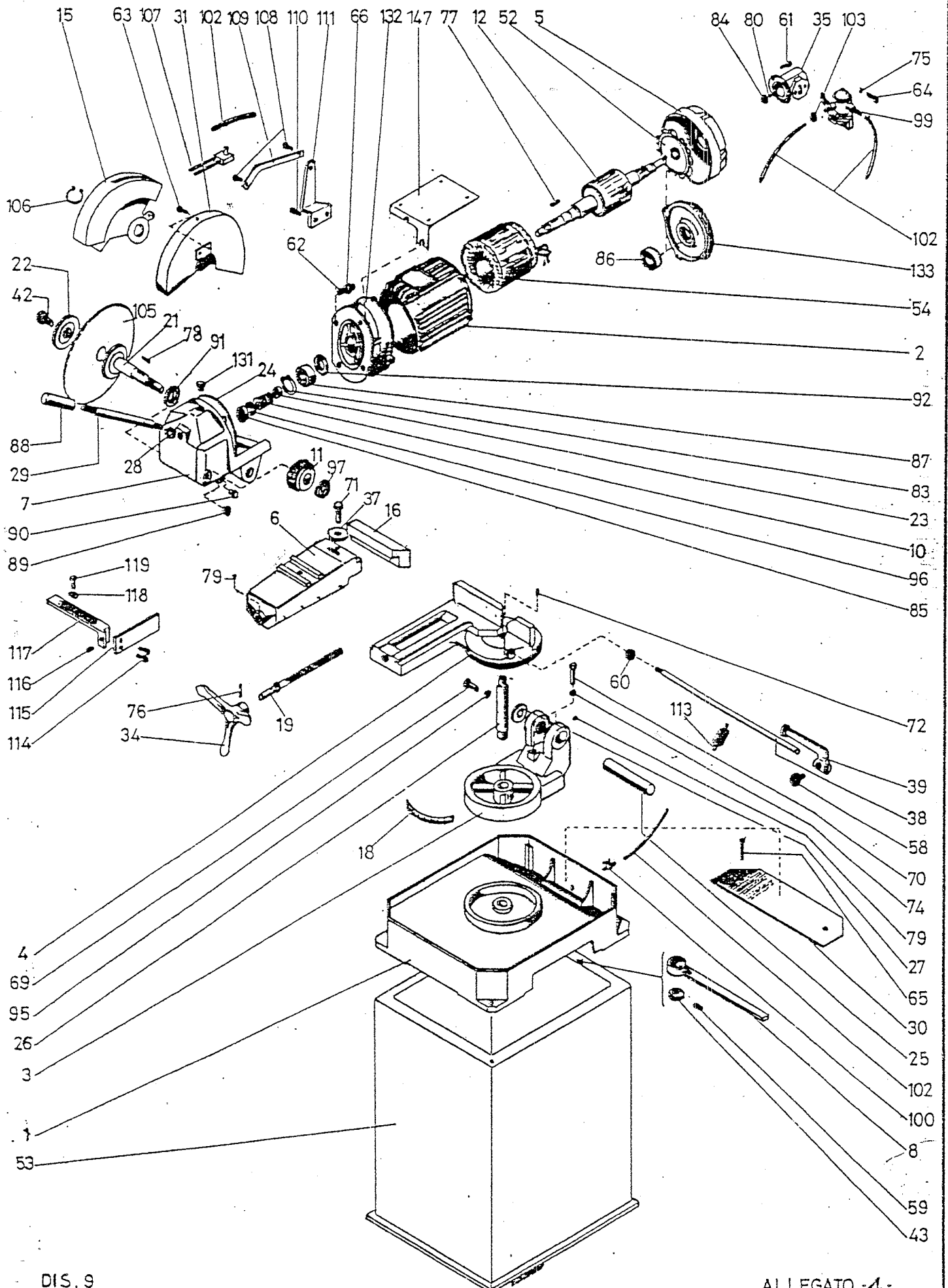

- SCELTA DELLE SEGHE - BLADE SELECTION
CHOIX DES FRAISES-SCIE - WAHL DER SAGEBLÄTTER

DIAMETRO - DIAMETER DIAMÈTRE - DURCHMESSER		200	225	250	275	300	315	350
SPESSORE - THICKNESS ÉPAISSEUR - DICKE		1.8	1.8	2	2.5	2.5	2.5	3
b = 10 - 80 g = ≤ 2	t	3	3	3	3	3	3	3
	z	200	230	250	280	300	320	350
b = 10 - 80 g = 2 - 4 d = 10 - 18	t	5	5	5	5	5	5	5
	z	130	140	160	170	190	200	220
d = 20 - 80 g = 4 - 10 d = 18 - 30	t	8	8	8	8	8	8	8
	z	80	90	100	110	120	120	140
d = 30 - 40	t	10	10	10	10	10	10	10
	z	60	70	80	90	90	100	110
d > 40	t	—	—	—	12	12	12	12
	z	—	—	—	70	30	80	90

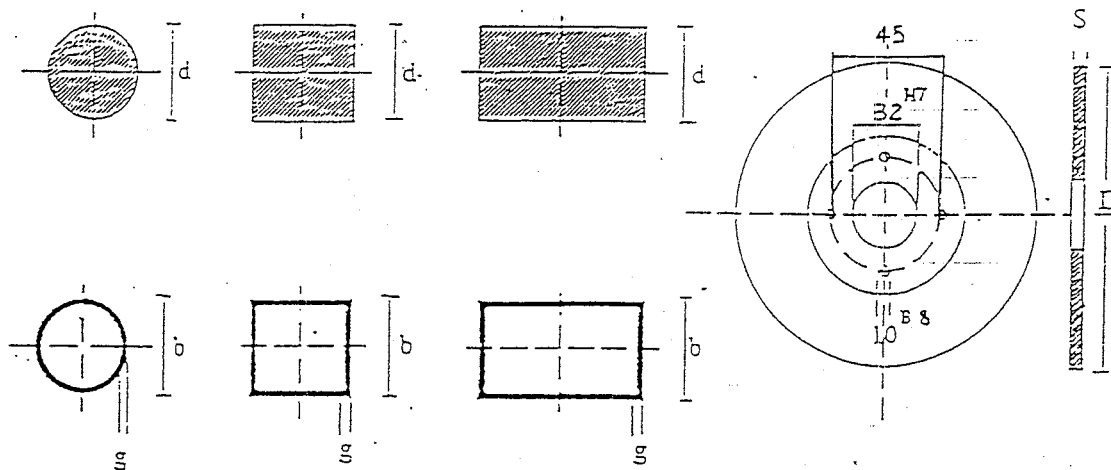

Si garantisce il funzionamento ottimale della vite-corona utilizzando seghe con fori di trascinamento.
Best performance of worm screw worm wheel gearing is guaranteed when circular saw blades with drawing-holes are used.

Nous garantissons le bon fonctionnement de la vis et couronne seulement si l'on emploie des fraise-scies avec trous d'entraînement.

Die verwendung von sageblättern mit mitnehmerlochern sichern den guten betrieb der schnecke und des scheinchenkranzes.

b = diametro esterno/altezza (tubi) - outside diameter/height (pipe)
diamètre extérieur/hauteur (tube) - aussendurchmesser/höhe (rohr)

d = diametro/altezza (pieni) - diameter/height (solid)
diamètre/hauteur (plein) - durchmesser/höhe (voll)

g = spessore del tubo - pipe thickness
épaisseur du tube - rohرداریcke

t = passo dentatura - toothing pitch
pas denture - entfernung verzahnung

z = numero di denti - number of teeth
numero de dents - zahnnummer

MOVIMENTAZIONE E TRASPORTO

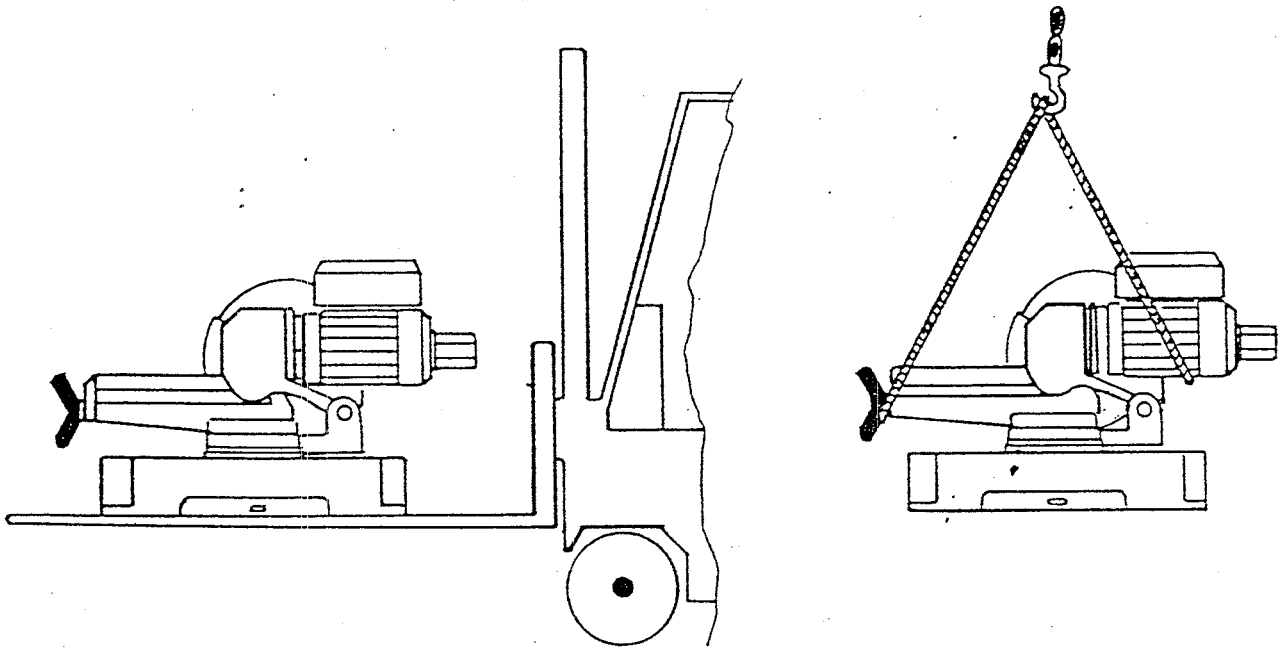

DIS. 1

PIANO DI INSTALLAZIONE

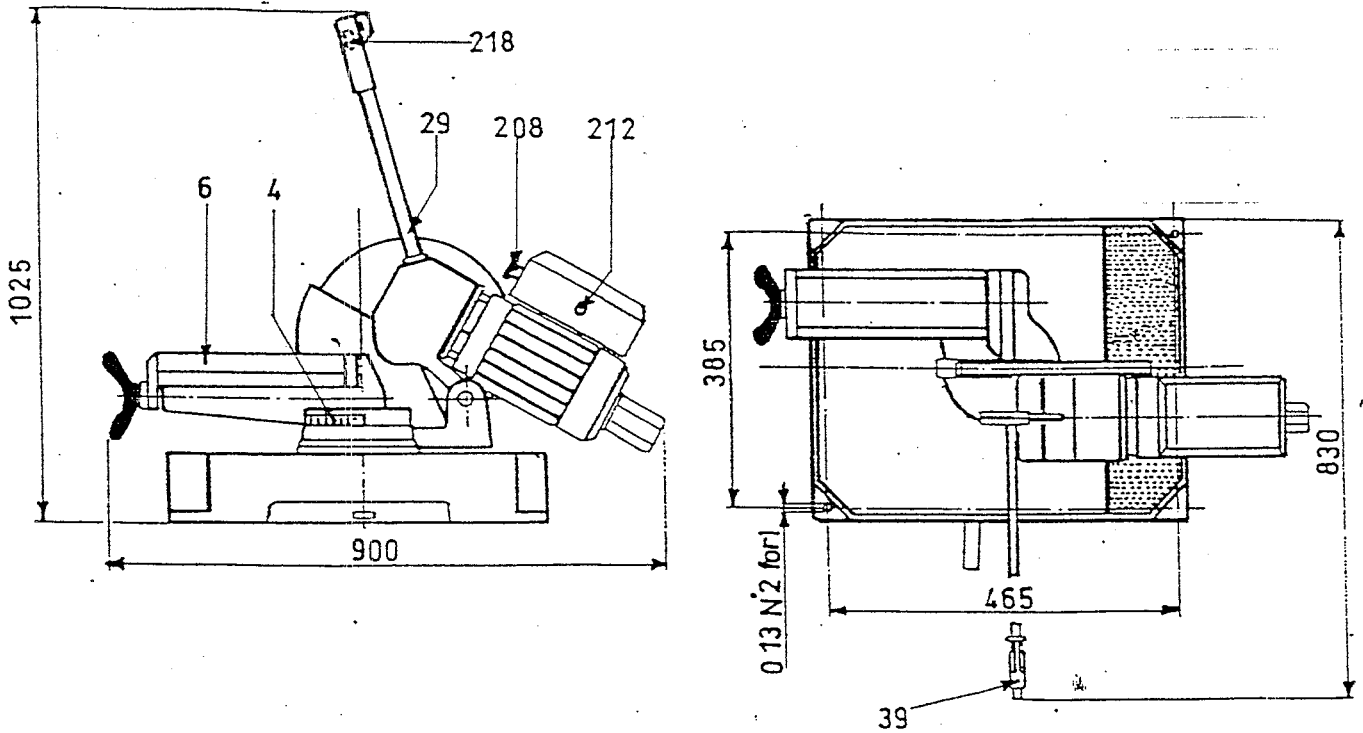

DIS. 2

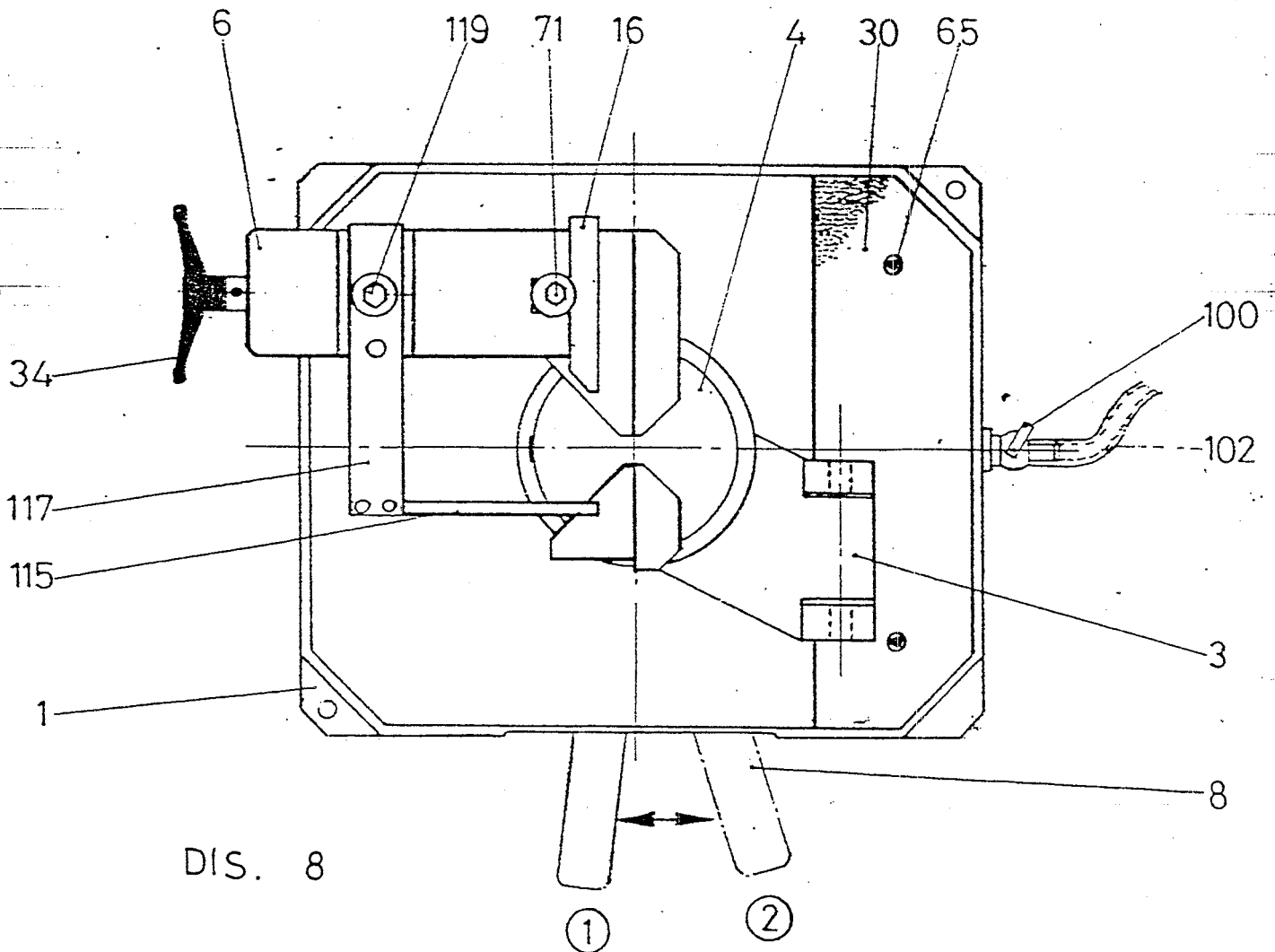
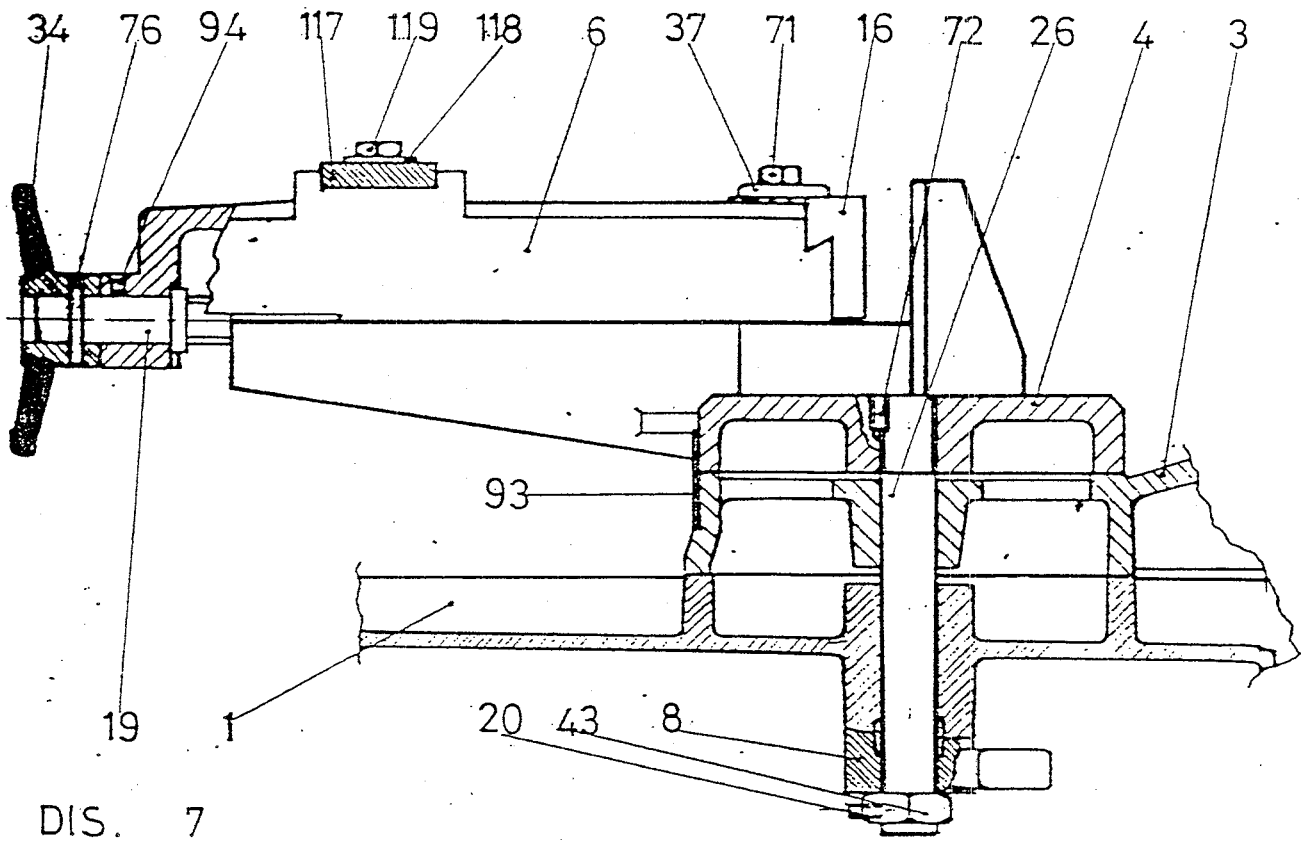

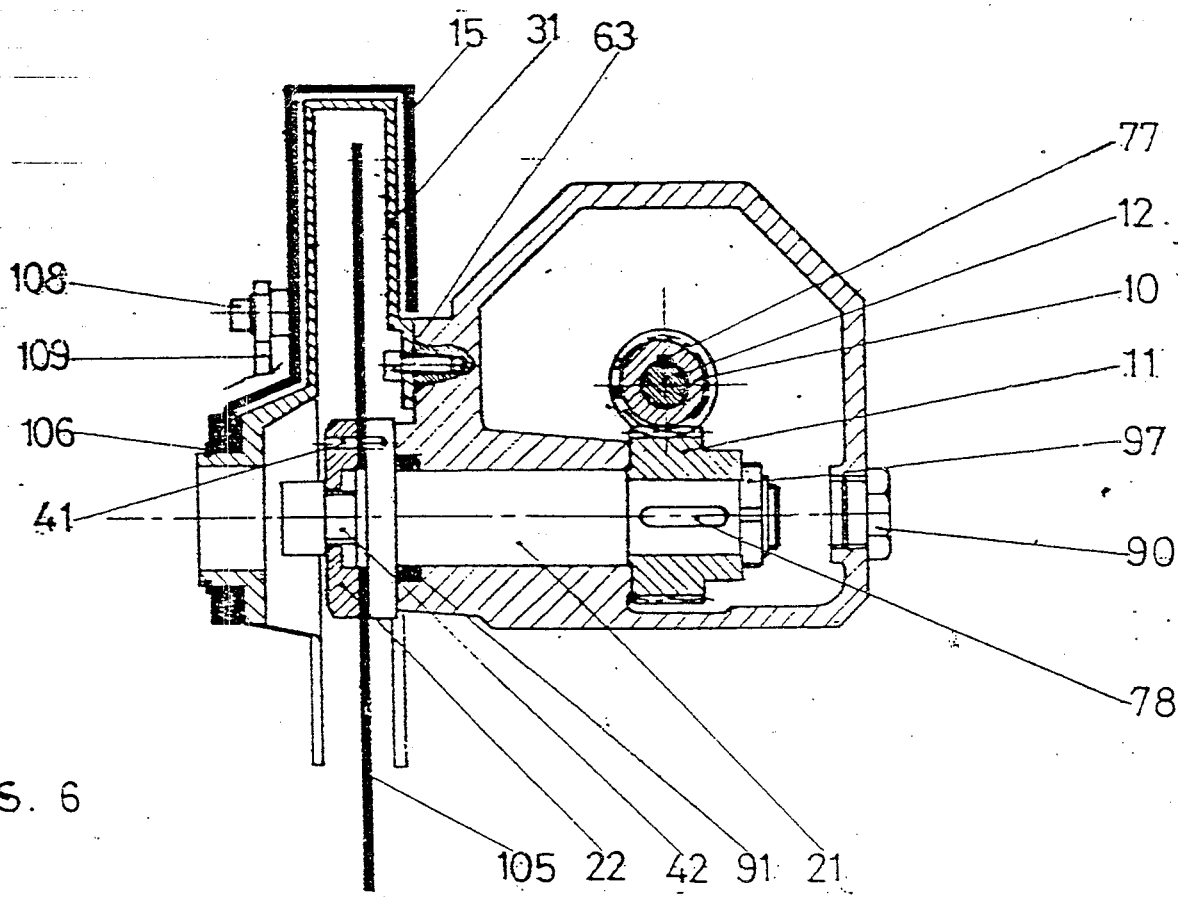
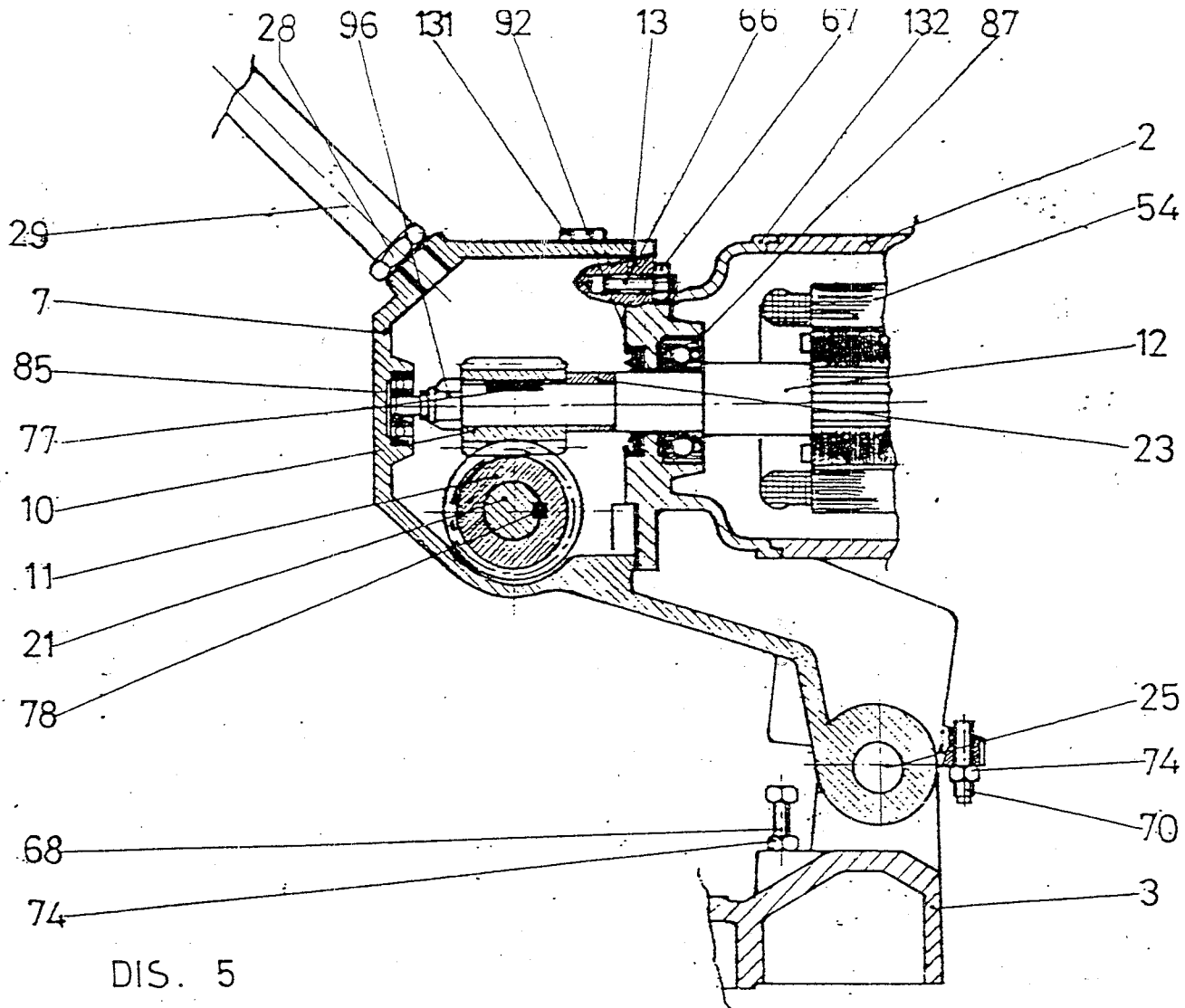

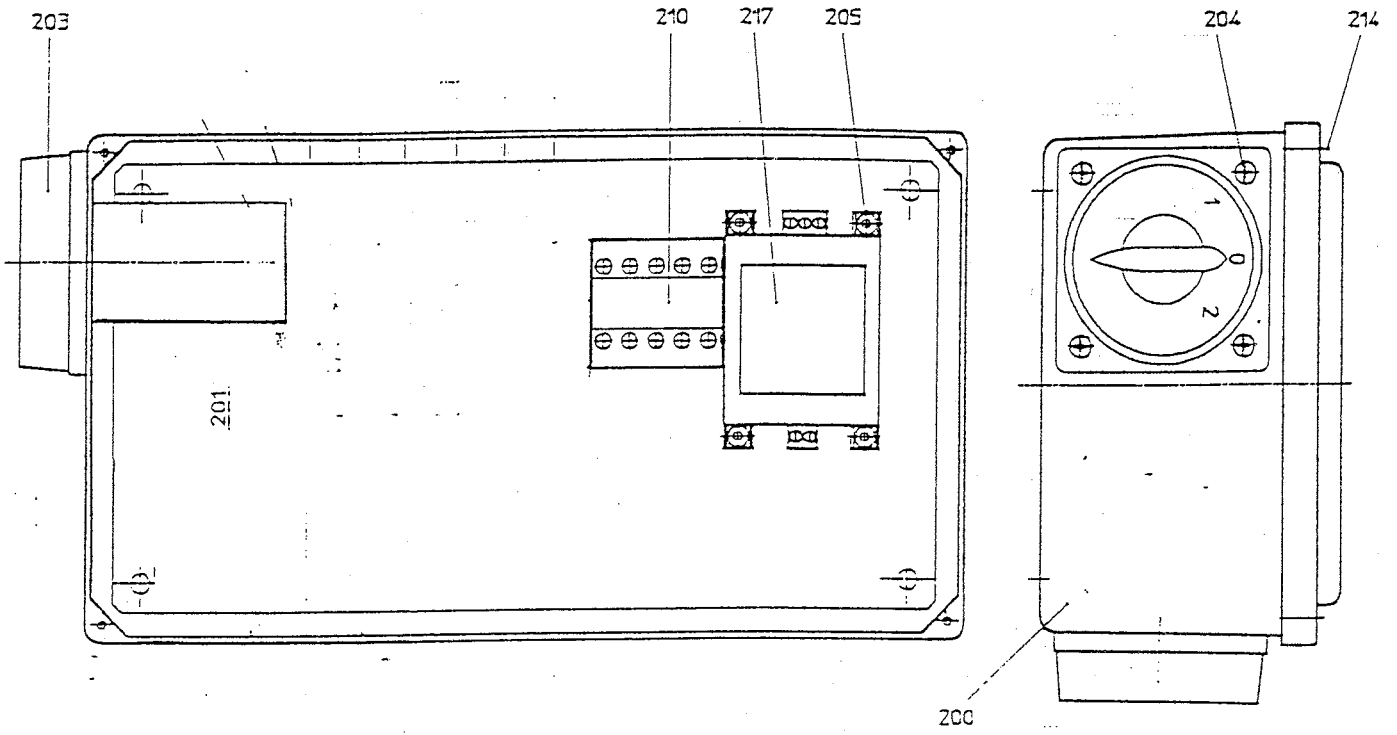

DIS. 3

Cassetta Impianto elettrico

Electric Box

Boîte Électrique

Schaltkasten

Caja Eléctrica

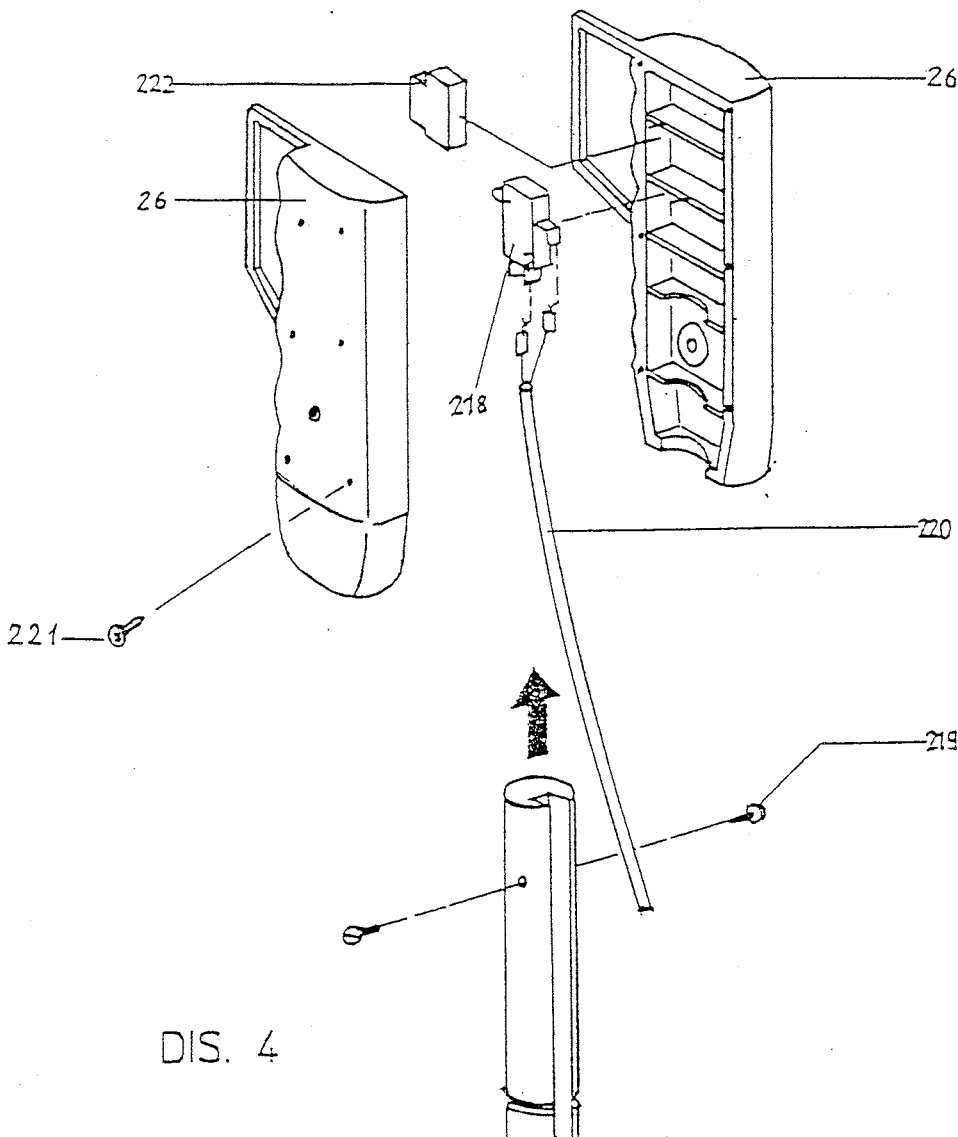

DIS. 4

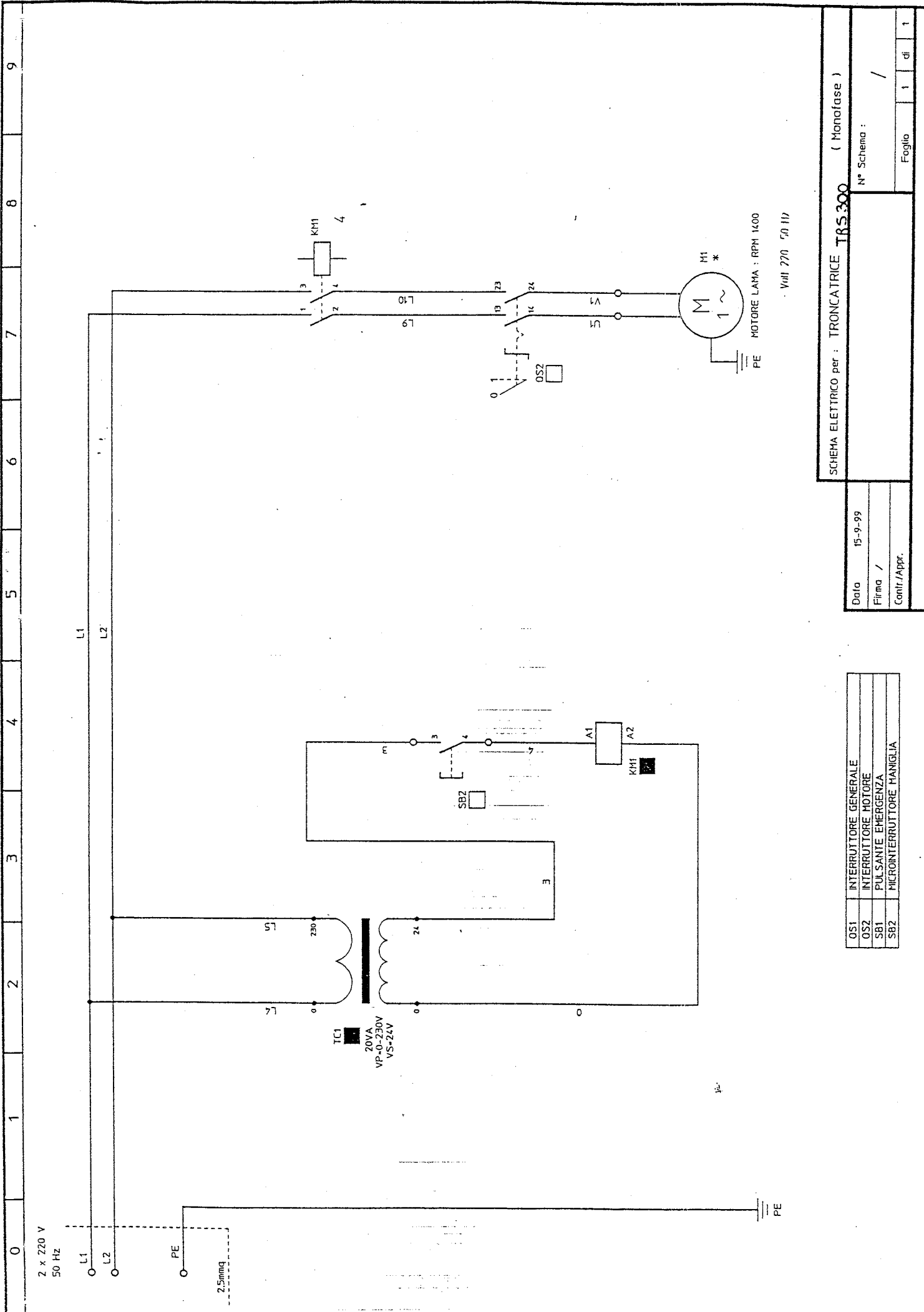

SCHEMA ELETTRICO per : TRONCATRICE TRS.300 (Monofase)	
Data	15-9-99
Firma	/
Contr./Appr.	
N° Schema :	/
Foglio	1 di 1

OS1	INTERRUTTORE GENERALE
OS2	INTERRUTTORE MOTORE
SB1	PUL.SANTE EMERGENZA
SB2	MICROINTERRUTTORE MANIGLIA

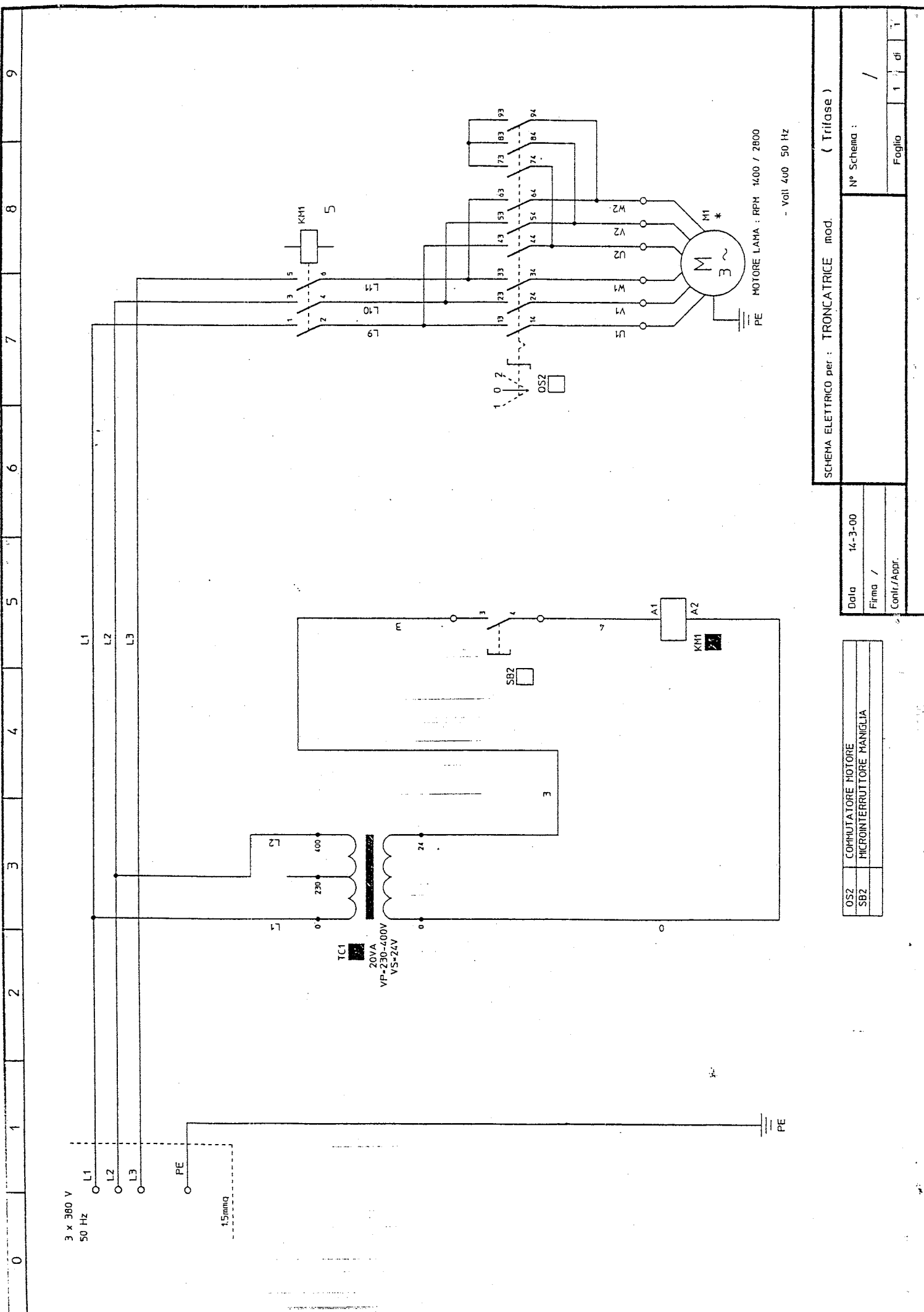

SCHEMA ELETTRICO per : TRONCATRICE mod. (Trifase)

N° Schema : /

Data 14-3-00

Firma /

Contr./Appr.

OS2	COMPUTATORE MOTORE
SB2	MICROINTERRUTTORE MANIGLIA